



SAILING INSTRUCTIONS

SNIPE CLASS INTERNATIONAL RACING ASSOCIATION (SCIRA)

JUNIOR SNIPE WORLD CHAMPIONSHIP 2024

Vieri Lasinio Di Castelveto Trophy

January 2-7, 2024

Coconut Grove Sailing Club (CGSC)

Miami, Florida, USA

[SP] denotes a rule for which a standard penalty may be applied by the race committee or technical committee without a hearing, or a discretionary penalty applied by the International Jury with a hearing. *This changes rule RRS 63.1, A4 and A5.*

[NP] denotes a rule that shall not be grounds for protests by a boat. *This changes RRS 60.1(a).*

1 RULES

The regatta will be governed by:

- 1.1 The rules as defined in the *Racing Rules of Sailing* (RRS).
- 1.2 Refer to NoR 1.5 and NoR Addendum 1 which state the only US Sailing prescriptions that apply.
- 1.3 The Rules of Conduct for Conducting National and International Championship (RoC) (https://www.snipe.org/images/2021/SCIRA_2021_Rules_of_Conduct_final.pdf) and the trophy restrictions of the “Vieri Lasinio Di Castelveto Trophy” (https://www.yachtscoring.com/event_documents/16009/Vieri_Lasinio_Di_Castelveto_Trophy.pdf) will apply. Any conflict arising between the Deed of Gift and the SCIRA Rules of Conduct shall be solved by the application of the Rules of Conduct.
- 1.4 Refer to NoR section 1 for other rules that are changed.
- 1.5 If there is a conflict between languages the English will take precedence.

2 CHANGES TO SAILING INSTRUCTIONS

- 2.1 Any change to the sailing instructions will be posted before 1000 on the day it will take effect, except that any change to the schedule of races will be posted by 2000 on the day before it will take effect.
- 2.2 Any change or amendment to the Sailing Instructions shall be approved with the SCIRA Representative.

3 COMMUNICATIONS WITH COMPETITORS

- 3.1 Notices to competitors will be posted on the Official Notice Board located on YachtScoring.com at https://www.yachtscoring.com/notice_board_summary.cfm?eID=16009
- 3.2 A competitors’ meeting will be held at 0900 on 3 January 2024 on the lawn at CGSC.

4. CODE OF CONDUCT

- 4.1 [DP] Competitors and support persons shall comply with reasonable requests from race officials.
- 4.2 [DP] Competitors and support persons shall place bow numbers supplied by the organizing authority with care, seamanship, in accordance with any instructions for their use and without interfering with their functionality.

5 SIGNALS MADE ASHORE

- 5.1 Signals made ashore will be displayed on the CGSC flagpole, at the base of the dock.
- 5.2 When the “AP” race signal is displayed ashore, ‘1 minute’ is replaced with ‘not less than **Error! Bookmark not defined.**60 minutes’ in the race signal “AP”. *This changes Race Signals.*
- 5.3 [DP] Flag D with one sound means ‘Boats shall not leave the harbour until this signal is made. The warning signal will not be made before the scheduled time or less than **Error! Bookmark not defined.**60 minutes after flag D is displayed.

6 SCHEDULE OF RACES

6.1 Dates of racing:

<u>Date</u>	<u>Time of Warning Signal</u>
2 January 2024	1400
3 January 2024 through 7 January 2024	1200 each day

Practice race
Racing (2 races scheduled each day,
except for 7 January when 1 race is
scheduled)

- 6.2 A total of nine (9) races are scheduled.
- 6.3 Last possible initial warning signal on the last day will be 1430.
- 6.4 To alert boats that a race or sequence of races will begin soon, the orange starting line flag will be displayed with one sound at least five (5) minutes before a warning signal is made.
- 6.5 If racing is behind schedule, an additional race may be run the next racing day. In no instance shall the racing get ahead of schedule.

7 CLASS FLAGS

7.1 The official Class Flag shall be the Snipe Class flag, a Snipe silhouette on a white background.

8 RACING AREAS

- 8.1 The intended race-course area will be on Biscayne Bay in an area approximately 1 to 3 miles SSE of Brennan Channel Marker "1" (FI G 5 sec. 8ft). See Attachment 1 for the location of the race-course area.
- 8.2 For RoC 16.1 application, the racing area is defined as "within 100 meters of: any boat racing, the starting/finishing lines, and all marks of the course." Team support persons shall stay outside the racing area from the time of the preparatory signal for the first start until all boats are finished or retired or the race committee signals a postponement, general recall or abandonment. On upwind legs, all support vessels shall stay to the right of the course (looking upwind).

9 THE COURSES

9.1 The diagrams below show the courses, including the approximate angles between legs, the order in which marks are to be passed. All course marks (except gates) shall be left to port.

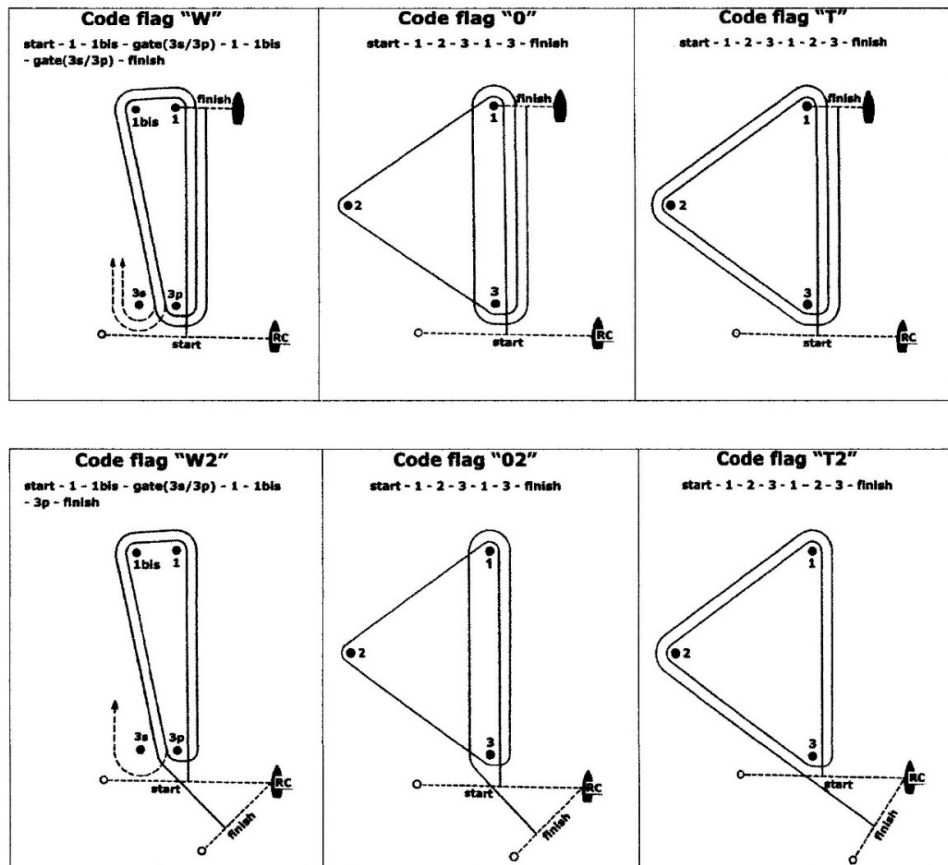

9.2 The course signal (code flag "W", "T", "O", "W2", "T2" or "O2") shall be hoisted with one sound at least one minute before the warning signal. It will remain displayed for not less than five minutes after the start.

2024 SCIRA Junior Worlds – Sailing Instructions

- 9.3 No later than the warning signal, the Race Committee signal vessel will display the approximate compass bearing of the first leg.
- 9.4 If during a race the wind and/or wave action changes to the point where the selected course would be inadvisable (See Course Selection Diagram), the Race Committee shall change the course at any mark. A change of the type of course during the race shall be signalled displaying the new appropriate flag and accompanied by repetitive sounds before the leading boat has passed or rounded the mark.
- 9.5 A sustained wind variation of 20 degrees or more from the posted bearing during the first leg of a race shall result in the race to be abandoned and re-sailed or abandoned. *This changes RRS 32.1.*
- 9.6 A sustained wind variation of 40 degrees or more from the posted bearing during the first lap shall result in the race being abandoned and re-sailed or abandoned. For the purpose of this rule, a lap means the rounding of mark 3 (or passing the gate 3s-3p) for the first time. *This changes RRS 32.1.*
- 9.7 The number of legs in a race may be reduced (RRS code flag S) but at least 2 (two) windward legs of the course shall be completed. *This changes RRS 32.2.*
- 9.8 The wind speed ranges shall be no less than 5 knots and not exceed 23 knots or in accordance with the Rules of Conduct for Conducting National and International Championships – the applicable Deed of Gift. *This changes RRS 32.1.*

10 MARKS

- 10.1 Marks 1, 1bis, 2, 3, 3s and 3p will be inflatable orange tetrahedrons.
- 10.2 New marks, as provided in instruction 13.1, will be inflatable yellow tetrahedrons.
- 10.3 The port-end starting mark will be:
a) a vessel with an orange flag displayed or,
b) an inflatable cylinder buoy.
- 10.4 The finishing mark will be:
a) mark 1 for “W”, “O”, and “T” courses,
b) a green inflatable tetrahedron for “W2”, “O2”, and “T2” courses.
- 10.5 Except at a gate, a Race Committee vessel signalling a change of a leg of the course is a mark as provided in SI 13.2.
- 10.6 If one of the marks "gate 3s-3p" is not placed, or is not replaced as per RRS 34, the remaining mark shall be left to port. *This changes RRS 34.*

11 AREAS THAT ARE OBSTRUCTIONS

- 11.1 There are no areas designated as an obstruction in the racing area.
- 11.2 On the way to the race area, there is a shallow area, designated with a white marker, that should not be sailed over. Attachment 1 shows the location with a yellow star.

12 THE START

- 12.1 The starting line will be between a staff displaying an orange flag on the Race Committee vessel at the starboard end and:
a) a staff displaying an orange flag on the starting mark as provided in instruction 10.3 a.
b) the course side of the starting mark as provided in instruction 10.3 b.
- 12.2 A boat starting later than 5 minutes after her starting signal will be scored Did Not Start without a hearing. *This changes RRS A4 and A5.*
- 12.3 RRS 30.4 is changed so that it may be applied in fleets with more than 45 boats and after the 2nd General Recall for that race. In the third sentence of RRS 30.4, “sail number” is replaced by “bow or sail number.”
- 12.4 The Race Committee, after the finish of a race and before the warning signal of a subsequent one, will do its best to post on the Race Committee vessel a list of OCS, ZFP, or UFD. The failure of posting or an incomplete or wrong list will not be grounds for redress. *This changes RRS 62.1(a).*

13 CHANGE OF THE NEXT LEG OF THE COURSE

- 13.1 To change the next leg of the course, the Race Committee will lay a new mark (or move the finishing line) and remove the original mark as soon as practicable. When in a subsequent change a new mark is replaced, it will be replaced by an original mark.
- 13.2 Except at a gate, boats shall pass between the race committee boat signalling the change of the next leg and the nearby mark, leaving the mark to port and the Race Committee vessel starboard. *This changes RRS 28.*
- 13.3 After the completion of the first windward leg of the race the remaining legs may be increased or decreased by not more than 30% of the original length. *This changes RRS 33.*
- 13.4 If Mark 1 will be changed in courses “W” or “W2”, Mark 1bis (offset) will no longer be a course mark.

14 THE FINISH

- 14.1 The finish line will be between a staff displaying a blue flag on a Race Committee vessel and the course side of the finishing mark.
- 14.2 The A flag on the Race Committee vessel at the finish means that there will be no more races for the day.

15 TIME LIMITS AND TARGET TIMES

- 15.1 The races will be managed to last 60-75 minutes for the first boat to finish. A different time (shorter or longer) used to complete the race will not be grounds for requesting redress. *This changes RRS 62.1.*
- 15.2 The time limit for the first boat to complete the first lap is 40 minutes from the start. If the first boat fails to complete the first lap within 40 minutes the Race Committee shall abandon the race. For the purpose of this rule a lap means the rounding of Mark 3 (or passing the Gate 3s/3p) for the first time.
- 15.3 The time limit for the first boat to finish the race shall be 1 hour, 30 minutes. Any boat finishing more than 30 minutes after the first boat finishes or failing to finish within 2 hours from the start, whichever is shorter shall be scored Did Not Finish (DNF). *This changes RRS 35, A4 and A5.*

16 HEARING REQUESTS

- 16.1 Protest/request for redress/scoring inquiry forms are online as described in SI 16.6-16.9.
- 16.2 Protestors shall use their sail numbers as identification on the protest form.
- 16.3 The protest/request for redress time limit is 90 minutes after the last boat finishes the last race of the day or the race committee signals no more racing today, whichever is later. The same protest time limit applies to all protests/requests for redress by the race committee and Jury. The time will be posted on the official notice board.
- 16.4 No later than 30 minutes after the protest time limit, notices will be posted to inform competitors of hearings in which they are parties or named as witnesses. Hearings will be held in the protest room, located in the dining room of CGSC beginning as soon as possible.
- 16.5 Rule 42 infringements will be posted by the Jury on the Official Notice Board before the protest time limit expires
- 16.6 Scoring inquiries, including potential redress requests relating to a starting penalty, should be initiated by filling out the online Scoring Inquiry form at <https://forms.gle/8NRwHJS4PAckzRTA7>
- 16.7 Questions about the status of scoring inquiries can be emailed to ScoringInquiry@cgsc.org. If a request for redress is based on the outcome of a scoring inquiry, then the redress time limit will have been satisfied if the Scoring Inquiry form was submitted before the redress time limit expired.
- 16.8 Protests and requests for redress unrelated to a starting penalty should be initiated by filling out the online Protest form at <https://forms.gle/nf2pk5BAaepPae36>
- 16.9 Additionally, if a diagram is required, it should be photographed and emailed to Protest@cgsc.org. Also, questions about the status of protests and redress requests can be emailed to Protest@cgsc.org. Notices will be posted on the official notice board no later than 15 minutes after the protest time limit to inform competitors of hearings in which they are parties to or named as witnesses. It is each boat's sole responsibility to check the Official Notice Board, https://www.yachtscoring.com/notice_board_summary.cfm?eID=16009 to see if they are cited in a protest. Representatives of boats who are parties to hearings and their witnesses shall remain on call until excused by the Protest Committee.
- 16.10 Notices of protests by the race committee, technical committee or protest committee will be posted on the Official Notice Board (as defined in SI 3.1) to inform boats under RRS 61.1(b).
- 16.11 The penalty for breaking rules in the SI marked with [SP] may be applied at the discretion of the Race Committee, without a hearing, and shall be the 5% scoring penalty for nearest race completed by the infringing boat but not worse than a DSQ. *This changes RRS 63.1 and A5.*
- 16.12 Penalties for breaking Class Rules may be less than disqualification. *This changes RRS 64.2.*
- 16.13 Per Appendix N2.2, SCIRA reserves for itself the right and responsibility to decide issues of eligibility, measurement and equipment. SCIRA may refer any issue to the International Jury for advice.
- 16.14 For the purpose of RRS 64.4(b) the "authority responsible" is the Measurer of the event.
- 16.15 The Jury will abandon the race if, during a redress hearing, they conclude that the Race Committee did not follow Sailing Instructions 9.5, 9.6, 9.7,9.8 and 13.3. *This changes RRS 64.3.*
- 16.16 A list of boats that have been penalized for breaking RRS 42, RRS 29.1(OCS) or 30.1(OCS) or 30.2(ZPF) 30.3(UFD), SI 17.5 and 17.6 will be posted on the Official Notice Board.

17 SCORING

- 17.1 Three (3) races are required to be completed to constitute a series.
- 17.2 If seven (7) races are completed, a competitor's worst score shall be excluded.

18 [NP][DP] SAFETY REGULATIONS

- 18.1 Before the warning signal of the first race of the day each boat is required to sail past the stern of the Race Committee Signal vessel displaying flag "L" on starboard tack and orally check in. When the Race Committee orally acknowledges a boat's sail or bow number, the check-in has been officially noted.
- 18.2 A boat that retires from a race shall notify the Race Committee as soon as possible.

19 REPLACEMENT OF CREW OR EQUIPMENT

- 19.1 The same crew shall race in all races, except for reasons satisfactory to the Race Committee. Requests for a change of crew shall be submitted in writing to the Principal Race Officer. Once a crew has been excused, he/she may not return for the balance of the series.
- 19.2 The same skipper shall sail all races and can be replaced after the first race only, and then only if he/she is obviously incapacitated. If a skipper is replaced the first race shall be the race dropped or scored DNC.
- 19.3 [DP] Substitution of hull, sails, appendages, and rig will not be allowed unless authorized in writing by the Race Committee. Requests for substitution shall be made to the committee at the first reasonable opportunity, which may be after the race.

20 OFFICIAL VESSELS

- 20.1 Official vessels will be marked as follows:
 - Race committee signal vessel - blue RC flag
 - Jury vessels with a "J" flag (blue with horizontal white stripe)
 - Mark set vessels - yellow RC flags.
 - Safety vessels - purple flag

21 [DP] RADIO COMMUNICATIONS

- 21.1 A boat that is racing shall not make voice or data transmissions and shall not receive voice or data communication that is not available to all boats, except in an emergency or when using equipment provided by the race committee.

22 [NP] [DP] TRASH DISPOSAL

- 22.1 Trash may be placed aboard support and Committee Vessels.

Posted 2023-12-27 at 2300

Principal Race Officer



Matt Bounds, NRO, USA

SCIRA Representative



Commodore Zbigniew Rakocy

ATTACHMENT 1 RACING AREA

